

Low profile foot with ankle joint and split toe.

Epirus

Features

- Multi-axial ankle motion with tripod stability
- Independent e-carbon foot springs
- Choice of PF and DF stiffness
- Ground compliance and energy efficient response
- Sandal Toe Footshell

Foot shell and glide sock included.



Specifications

Max. User Weight:	125kg
Activity Level:	(2), 3, (4*)
Size Range:	22cm-30cm
Component Weight:	400g [†]
Build Height:	85mm
Heel Height:	10mm



Suitable for outdoor use

Order Example

Product Code	Size	Side	Width*	Spring Set	Sandal Toe
EP	25	L	N	3	S

*Narrow (N) and Wide (W) available for sizes 25-27 only.
For dark tone add suffix D.
Example: foot size 25, left, narrow, spring rating 3, sandal toe.

Build Height

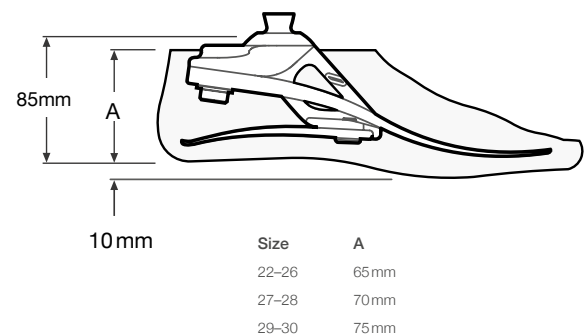

Activity Level 2 and 4* users who would benefit from this foot will require softer or stiffer springs as appropriate for the individual. Refer to Instructions for Use for further information.

Spring set recommendations are for trans-tibial users. For trans-femoral we suggest selecting a spring set one level lower.

Activity
3

User Weight

44-52	53-59	60-68	69-77	78-88	89-100	101-116	117-125	kg
100-115	116-130	131-150	151-170	171-195	196-220	221-255	256-275	lbs

1	2	3	4	5	6	7	8
---	---	---	---	---	---	---	---

Spring set



*Maximum user weight 100kg and always use one higher spring rate category than shown in the Spring Set Selection table.

[†]Component weight shown is for a size 26cm without foot shell.